

Product Information Bulletin

64 Outwater Lane, Garfield, NJ 07026 Ph: 973-340-7889 | Fax: 973-340-7809

Adjustable U-Channel Post Bracket

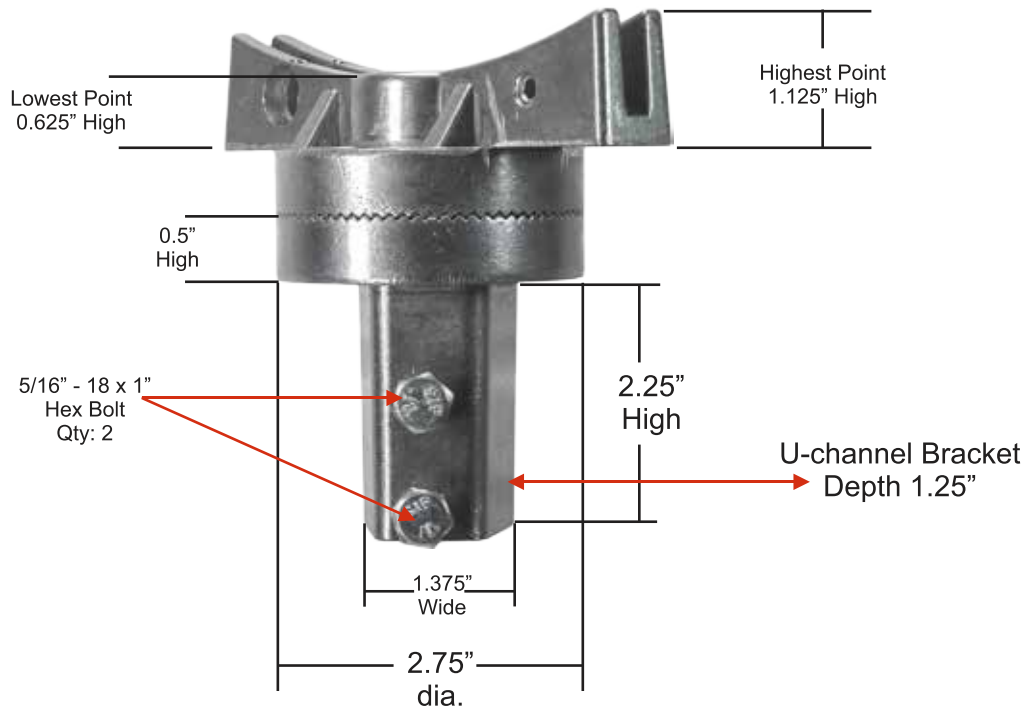

Dimensions for Flat and Extruded Blade Bracket

Brimar Part# Y3506 & Y3507

- Adjustable U-Channel Post Cap
- Rotates full 360°
- Exclusive locking teeth can be clamped at any angle

INCLUDED:

5/16" - 18 x 1/2" Set Screw / Qty: 2

5/16" - 18 x 1" Hex Bolt / Qty: 2

INSTALLATION:

- 9/16" clearance holes allow secure and balanced installation
- 25-40 pounds of pressure is sufficient to secure sign
- Fasteners come pre-installed

QUALITY:

- Die Cast Brackets are cast from high strength aluminum under 400 tons pressure.
- Tensile strength 45,000 P.S.I. tumbled and degreased for smoothness and ease of handling.

DATE: ___ / ___ / ___ JOB: _____

CONTRACTOR: _____