

Product Information Bulletin

64 Outwater Lane, Garfield, NJ 07026 Ph: 973-340-7889 | Fax: 973-340-7809

Round Post Street Name Sign Bracket

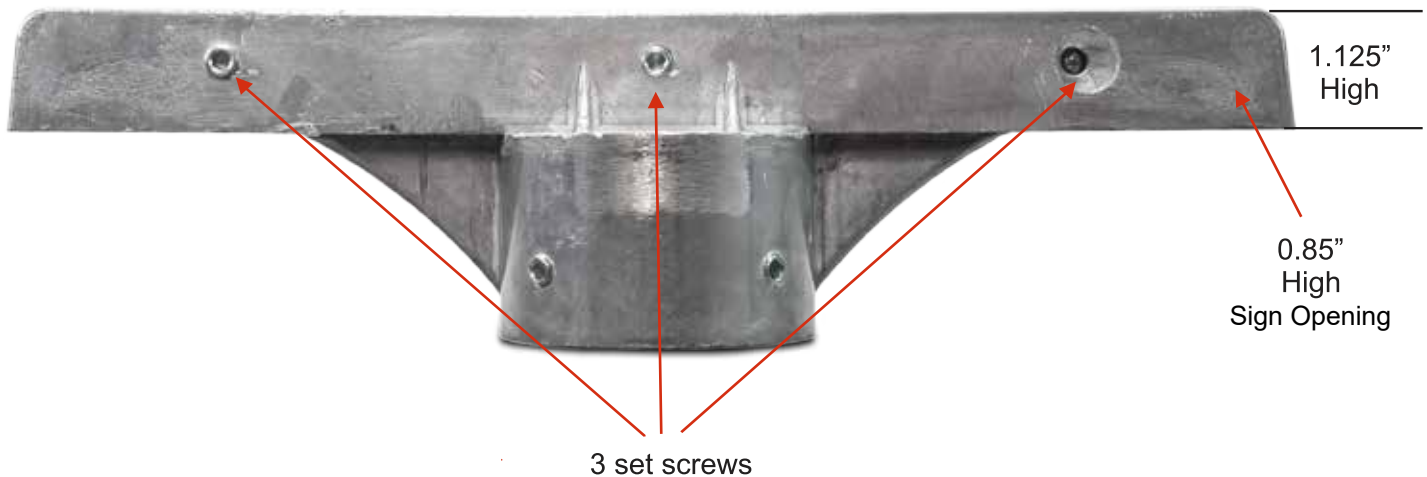

Dimensions for Flat and Extruded Blade Bracket

Brimar Part# Y3502-R12F & Y3502-R12E

- 2-3/8" diameter Round Post Street Name Bracket
- Weight 1.45 lbs

INCLUDED:

Sign Holder: 5/16" - 18 x 1/2" Set Screw / Qty: 3
Bracket Body: 5/16" - 18 x 1/2" Set Screw / Qty: 3

INSTALLATION:

- 9/16" clearance holes allow secure and balanced installation
- 25-40 pounds of pressure is sufficient to secure sign
- Fasteners come pre-installed

QUALITY:

- Die Cast Brackets are cast from high strength aluminum under 400 tons pressure.
- Tensile strength 45,000 P.S.I. tumbled and degreased for smoothness and ease of handling.

DATE: ___ / ___ / ___ JOB: _____

CONTRACTOR: _____